



GM730

Senstec™

Seismic detector

low-profile seismic detector for applications on steel and concrete

- **Around-the-clock monitoring of safes, night deposits and automatic teller machines**
- **Individual settings with SensTool software**
- **Easy test of installation and operation with external test transmitter GMXS1**
- **SENSTEC™ Bimorph sensor and intelligent micro-controller-based signal evaluation**

Versatile in application. The low-profile design makes it easy to install. Predefined settings allow to be quickly set for all common applications. Optional SensTool software enables modification of default operating parameters and monitoring of current detector performance.

Effective. The GM730 reliably recognises attacks with explosives or attempted entry using modern tools, such as diamond-tipped drills, mechanical and hydraulic pressure tools, flame cutters, thermal-lances or water jet on safes, automatic teller machines, night deposits and strong rooms.

Highly professional. The patented SENSTEC™ sensor and digital signal processing evaluates a selected narrow frequency band to ensure reliable detection. This comprehensive protection is immune to environmental influences including air and structure borne noise from external disturbance sources.

Fire & Security Products

Siemens Building Technologies

Accessories and dimensions

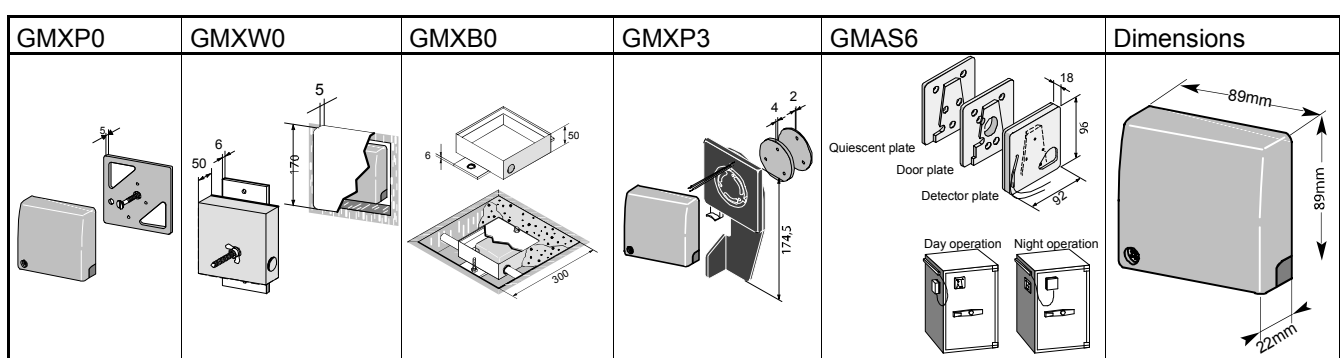

Technical data

Detection characteristics	
- Operating radius/Coverage area on concrete and steel	
- For all types of tools (including termic tools)	4m / 50 m ²
Power supply	
- Voltage monitoring	8 ... 16 VDC (12 V nom.)
- Alarm	< 7 VDC
Power consumption (at 12 VDC)	
- Quiescent / Alarm	3 mA / 5 mA
Alarm output	
- Relay (opens on alarm)	30 VDC / 100 mA / Ri < 20 Ω
- Alarm hold time	ca. 2,5 s
Tamper output	
- Cover contact (opens on tamper)	30 VDC / 100 mA / Ri < 45 Ω
Test point output	
	analogue integration signal
Function test	
- For test	LOW ≤ 1,5 VDC / HIGH ≥ 3,5 VDC
- Test duration	≤ 3 s
Remote sensitivity reduction input	
- For reduction	LOW ≤ 1,5 VDC / HIGH ≥ 3,5 VDC
- Reduction to	1/8 of the actual setting
Adjustments	
- Dip switch settings	3 levels
- Via SensTool PC Software	freely programmable
Environmental conditions	
- Operating temperature	- 40 ... + 70°C
- Storage temperature	- 50 ... + 70°C
- Air humidity (EN 60721)	< 95% rh, non-condensing
- Housing protection (EN 60529, EN 50102)	IP435
- Electromagnetic compatibility (EMC)	better than EN 50130-4
- Tolerance of HF interference	
1 ... 2000 MHz (EN 61000-4-3)	> 30 V/m

Ordering data

Type	Art. No.	Designation	Weight
GM730	A5Q00005841	Seismic detector	0,330 kg
GMXP0	277273	Mounting plate	0,270 kg
GMXS1	420237	Test transmitter	0,020 kg
GMXW0	277121	Wall recessed w/cover	1,160 kg
GMXB0	277202	Floor box w/cover	2,085 kg
GMXP3	347019	Swivel plate	0,525 kg
GMAS6	488606	Fixing device	0,400 kg
GMXD7	A5Q00006245	Drilling protection (set of 10 pcs)	0,080 kg
GMSW7	A5Q00006246	SensTool Interface and software	

Siemens Building Technologies AG
 Alte Landstr. 411
 CH-8708 Männedorf
 Tel. +41 1 - 922 6111
 Fax +41 1 - 922 6450
www.sbt.siemens.com

© 2004 Copyright by
 Siemens Building Technologies AG

Data and design subject to change without notice. Supply subject to availability

Document no. **008263_a_en_--**
 Edition 05.2004

Manual -
 Section -